

Psychometric properties and validation of the Satisfaction With Life Scale in psychiatric and medical outpatients in Malaysia

Sinniah Aishvarya^{a,b,*}, Thambu Maniam^a, Chinna Karuthan^c, Hatta Sidi^a,
Nik Ruzyanei Nik Jaafar^a, Tian Po Sumantri Oei^b

^aUniversiti Kebangsaan Malaysia Medical Centre, Malaysia

^bUniversity of Queensland, Australia

^cUniversiti Malaya, Malaysia

Abstract

The present study evaluated the psychometric properties and factor structure of the Satisfaction With Life Scale (SWLS) in a sample of clinical outpatients in Malaysia. The SWLS is a measure designed to assess subjective life satisfaction. Four hundred eighty-three participants (283 with psychiatric illnesses and 200 with other medical illnesses) completed the SWLS and other self-report instruments. Results of the EFA and CFA supported the fit for the one-factor model as the best-fitting model. The internal consistency of the SWLS ($\alpha = 0.86$) was found to be high. Correlational analyses showed that SWLS had adequate concurrent validity. Scores on SWLS, which differentiated psychiatric patients and medical patients, supported criterion validity. The logistic regression analyses showed good discriminative validity of SWLS. The SWLS is a reliable and valid instrument to measure the satisfaction with life among psychiatry and clinical outpatients in Malaysia.

© 2014 Elsevier Inc. All rights reserved.

1. Introduction

One of the important topics in psychology is subjective well-being, which includes two broad aspects: an affective component and a cognitive component [1]. The affective component of subjective well-being refers to pleasant affect and unpleasant affect [2] whereby these levels are used to indicate the level of subjective well-being. Meanwhile the cognitive component is referred to as life satisfaction [3]. According to Shin and Johnson [4] life satisfaction is a judgmental process whereby an individual assesses his/her quality of life based on his/her own unique set of criteria. It is also a conscious cognitive judgment whereby the criteria for judgment are up to the person [2].

In the year 1985, Diener et al. [3] developed the Satisfaction with Life Scale (SWLS) with five statements (“In most ways my life is close to ideal,” “The conditions of my life are excellent,” “I am satisfied with my life,” “So far, I

have gotten the important things I want in life,” “If I could live my life over, I would change nothing”) to assess satisfaction with one’s life. The SWLS is rated on a Likert scale from 1 (strongly disagree) to 7 (strongly agree). According to Oishi [5] the SWLS is one of the most popular scales used to measure life satisfaction since its psychometric properties have been extensively examined in various populations. The higher scores on the SWLS indicate higher level of life satisfaction with a score above 30 representing high satisfaction and a score between 5 and 9 indicating extreme dissatisfaction with life. The neutral point of the scale is 20, which indicates that a person is neither satisfied nor dissatisfied with life [2].

Since 1985, the psychometric properties of SWLS have been studied extensively with numerous studies [1,3,5–8]. The internal consistency of SWLS was generally higher than the value of .80 [3,7,9]. Meanwhile, the convergent and discriminant of this scale showed that SWLS correlates with other measuring well-being but remaining as a separate construct [1–3,10,11]. As conceptualized by Diener et al. [3], several factor-analytic studies supported the uni-dimensional structure model of the SWLS [12–14].

In Malaysia, Swami and Chamorro-Premuzic [15] examined the psychometric properties of Malay SWLS in a

Publication of this supplement was supported by Universiti Kebangsaan Malaysian Medical Centre, Kuala Lumpur, Malaysia.

* Corresponding author.

E-mail address: aishvarya_arun@yahoo.com.my (S. Aishvarya).

community sample of 816 Malay and 738 Chinese populations. The results showed that the Malay SWLS had good internal consistency (Cronbach $\alpha = 0.83$) with confirmatory factor analysis supporting a uni-dimensional factor structure of SWLS, which remained invariant across gender and ethnic groups of the general population.

To date no studies has been conducted among clinical outpatient samples to examine the factor structures and other psychometric properties of SWLS in Malaysia. By validating this scale, it can be used among clinical patients especially among psychiatry patients and mental health professionals can include the aspect of satisfaction of life in the management of patients. Thus, our study was designed to (a) examine the factor structure and psychometric properties of SWLS in a sample of adult psychiatric and medical outpatients in Malaysia and (b) examine the reliability and validity of SWLS with other measures of suicide behavior and general psychopathology.

2. Method

2.1. Participants

A total of 483 psychiatric and medical outpatients from Universiti Kebangsaan Malaysia Medical Centre (UKMMC) participated in this study. UKMMC is a semi-government hospital, which is located in Cheras, Kuala Lumpur. It is also the teaching hospital for the Universiti Kebangsaan Malaysia and a national tertiary hospital, which receives referral cases from district hospitals, government primary health clinics and private clinic from all over Malaysia. Participants aged between 18 and 76 years with the diagnosis of depressive disorders, anxiety disorders or co-morbid anxiety and mood disorders as defined by the DSM-IV and who gave written consent to participate were included in this study. Patients were excluded if they were too psychotic or ill to be interviewed, did not give written consent or could not comprehend in Bahasa Malaysia or English.

The 283 psychiatric patients consisted of 203 (42.0%) patients diagnosed with some form of mood disorders, 65 (13.4%) with anxiety disorders, 15 (3.1%) co-morbid anxiety and mood disorders. The remaining 200 medical patients were outpatients coming to hospital for medical illnesses.

2.2. Measures

Participants completed a brief demographic questionnaire, the Satisfaction With Life Scale (SWLS) and seven other self-report instruments (The Depression Anxiety Stress Scale-21, Reasons for Living Inventory, Beck Hopelessness Scale, Rosenberg Self-Esteem Scale, Positive and Negative Suicide Ideation Inventory, Provision of Social Relations, The Adult Trait Hope Scale). The Mini International Neuropsychiatric interview [16] was administered by the first author of this study to every 10 patients to confirm the diagnosis given by their psychiatrist. This is also to ensure

that patients who attended other clinics such as medical clinics, ear, nose and throat (ENT) clinics, ophthalmology clinics and orthopedic clinics did not have any psychiatric illnesses. A kappa value of 0.784 was found and the percentage of agreement was 81.9% for patients with mood disorders, 100% for patients with anxiety disorders and 100% for patients with the diagnosis of co-morbid mood and anxiety disorders.

2.3. Procedure

2.3.1. Psychiatry patient sample

Patients who attended psychiatry clinics for follow-up appointments, new cases and emergency cases with the diagnosis of mood disorders, anxiety disorders and co-morbid mood and anxiety disorders were approached to participate in this study. A total of 971 patients were approached based on their diagnoses as above, however 211 declined due to certain reasons: unable to read either Bahasa Malaysia or English, unable to concentrate or discontinued after being called by their respective psychiatrists for consultation. Four hundred and forty five patients refused to fill up without giving any specific reasons. A total of 283 patients with any of the three diagnoses as above participated in this study after obtaining their written consent. The first author of this study further evaluated the earlier diagnosis using The Mini International Neuropsychiatric Interview (MINI) for every 10 patients to confirm the diagnosis given by their psychiatrist. Patients took approximately 45 min to complete the entire set of questionnaires. A total of 168 patients filled up the questionnaires in English and 115 in Bahasa Malaysia.

2.3.2. Medical patient sample

Medical patients recruited in this study were from medical clinics, ear, nose and throat (ENT) clinics, ophthalmology clinics and orthopedic clinics. A total of 247 patients were approached in the clinics while waiting for their consultation with their respective doctors. Twenty-seven patients declined for not being able to read in Bahasa Malaysia or English and the remaining 20 had some form of psychiatric illnesses. Two hundred patients without any psychiatric illnesses participated in this study after obtaining their written consent. The Mini International Neuropsychiatric Interview (MINI) for every 10 patients to identify if participants had any psychiatric illness. Patients took approximately 45 min to complete the entire set of questionnaires. A total of 93 patients filled up the questionnaires in English and 107 in Bahasa Malaysia.

2.3.3. Translating and back-translating procedure

A team of four consisting of two bilingual clinical psychologists (both possess a master's degree qualification), and two psychiatry registrars, independently translated and back-translated the English version of the study measures. Subsequently, the questionnaires were proofread by a professional language interpreter to identify and

reconcile any language discrepancy derived from the translation procedure.

2.4. Ethical approval

All participants gave their signed informed consent before undertaking the assessment. Ethical approvals were obtained from the research ethic committees belonging to Universiti Kebangsaan Malaysia Medical Centre (Project Code: FF-251-2010) and Behavioral & Social Sciences Ethical Review Committee of University of Queensland (Project No: 2010001093).

2.5. Data analysis

Data in this study were analyzed using the Statistical Program for the Social Sciences version 15.0 and AMOS version 20.0. Data screening was done with descriptive statistics. Meanwhile, Cronbach alpha was used to evaluate the reliability. Correlations were used to analyze the concurrent validity of PANSI. The discriminant validity, specificity and sensitivity of the PANSI were analyzed using logistic regression analysis.

The factor structure of PANSI was examined using the exploratory factor analysis (EFA). Meanwhile the Kaiser–Meyer–Oklin (KMO) value and correlation matrix were used to examine the suitability of the data for factor analysis. A KMO value of 0.7–0.8 and above is considered good for factor analysis. The CFA model fit was tested using a few alternative statistics methods. A good model fit has low chi-square goodness of fit and is statistically not significant. In addition, an acceptable model has a value of $SB-\chi^2/df$ (chi-square divided by its degrees of freedom) of < 3. Other indices were Goodness-of-Fit Index (GFI), Adjusted-Goodness-of-Fit Index (AGFI), Comparative Fit Index (CFI) and the Root Mean Square Error Approximation Index (RMSEA). The AGFI and CFI should be > 0.90 and if the RMSEA is < 0.08 the fit is acceptable [17].

3. Results

3.1. Assumption testing

Before conducting the primary analyses, all data cleaning and descriptive analysis were conducted. Data cleaning included checking the accuracy of data entry, missing values, outliers and assumptions of multivariate analysis. No outliers and assumptions of multivariate analysis were found. The missing values were fewer than 5% and seemed to be distributed randomly across the remaining cases. Skewness and kurtosis statistics were used to assess the frequency distributions and it indicated that departures from normality were minimal.

3.2. Descriptive analyses

A total of 483 participants were recruited for this study with 188 (38.9%) male and 295 (61.1%) female patients. The

Table 1

Pattern matrix of exploratory factor analysis and Cronbach alpha for SWLS.

Item no.	Title	Factor	Communalities
3	Satisfied with life	.890	.793
1	Life is close to ideal	.840	.706
2	Conditions of life are excellent	.815	.665
4	Gotten the important things	.743	.552
5	Will change almost nothing	.553	.305
Eigenvalues		3.38	
Percent of variance		67.58	
Cronbach alpha		0.86	

SWLS, Satisfaction With Life Scale.

sample consisted of 203 (42%) patients diagnosed with mood disorders, 65 (13.4%) with anxiety disorders, 15 (3.1%) with co-morbid anxiety and mood disorders, and 200 (38%) with other clinical diagnosis except psychiatric diagnosis. The participants' ages ranged from 16 to 75 years, with a mean of 42 years. The marital status of the participants included single (26.2%), married (62.1%), divorced (5.6%), widowed (1.6%), separated (1.5%) and 3% without the marital status. Two hundred fifty-eighty (53.4%) of the participants were Malays followed by Chinese 157 (32.5%), Indians, 53 (11%) and finally other races, 15 (3.1%). The educational background of the participants included matriculation/pre-university/college/STPM (60%), and high school certificate level (38.3%), 1.4% of the participants had only completed primary school and 0.4% without any formal education. A total of 261 (54%) subjects filled up the English version questionnaires and the rest in Bahasa Malaysia version.

3.3. Exploratory factor analysis

A sample size of 168 was used for EFA for SWLS in this study. According to Tabanick and Fidell [18], 150 cases should be sufficient for factor analysis if solutions have

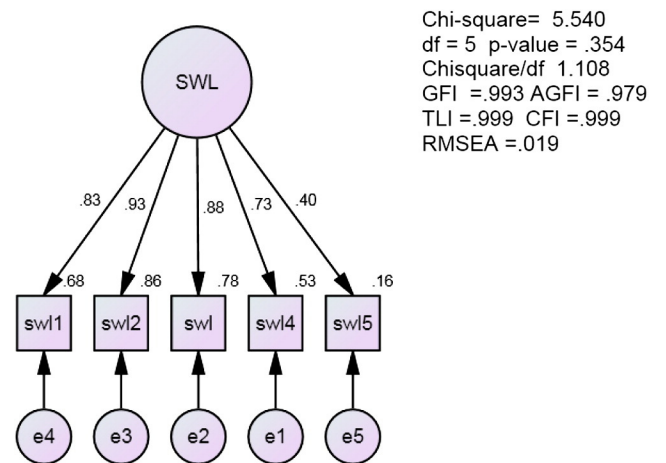

Fig. 1. Standardized regression weight for items in SWLS. SWLS, Satisfaction With Life Scale; *df*, degree of freedom; chi-square/*df*, chi-square divided by its degrees of freedom; GFI, Goodness-of-Fit Index; AGFI, Adjusted Goodness-of-Fit Index; CFI, Comparative Fit Index; RMSEA, Root Mean Square Error Approximation Index; TLI, Tucker–Lewis Index.

Table 2
Comparisons of different factorial models for SWLS.

Model	χ^2	df	χ^2/df	CFI	RMSEA
1. Swami and Chamorro-Premuzic	35.9	5	7.18	.99	.06
2. Bai et al.	574.08	4	143.52	.99	.09
3. Glaesmer et al.	212.74	5	42.5	.98	.07
4. Aishvarya et al.	5.540	5	1.108	.99	.02

1. Malay community sample; 2. sample of participants in China; 3. German general population; 4. psychiatry and medical outpatients.
SWLS, Satisfaction With Life Scale; *df*, degree of freedom; χ^2 , chi-square; χ^2/df , chi-square divided by its degrees of freedom; CFI, Comparative Fit Index; RMSEA, Root Mean Square Error Approximation Index.

several high loading marker variables (above 0.80). Meanwhile the suitability of data for factor analysis was assessed. The correlation matrix showed the presence of many coefficients of 0.4 and above. The Keiser–Meyer–Olkin value was 0.841 exceeding the recommended value of 0.6 [19] indicating sampling adequacy. The significant value ($1 < 0.001$) of Barlett’s test of sphericity also supported the factorability of the correlation matrix and the data were decided to be suitable for factor analysis. The number of factors to retain was based on several criteria such as having minimum eigenvalues of 1, minimum factor loadings of 0.40 and minimal factorial complexity. In addition to above, the factors need to be interpreted meaningfully.

The EFA results are summarized in Table 1. As can be seen from Table 1, the single-component solution was explained by a total of 68% of the variance. When Promax rotation was performed, all items loaded strongly on one-factor solution.

3.4. Confirmatory factor analysis

The remaining 315 patients from the total sample were used for confirmatory factor analysis for SWL. Using the five items of SWL, a good fit of the unidimensional model to the data was obtained ($\chi^2 = 5.540$, $df = 5$, $SB-\chi^2/df = 1.108$, $p = .000$, $GFI = .993$, $AGFI = .979$, $CFI = .999$, $RMSEA = .019$) (see Fig. 1). CFA was also used to test three other models suggested by Swami and Chamorro-Premuzic [15], Bai et al. [20], and Glaesmer et al. [8] and the results in Table 2 showed that the four models also supported the uni-dimensional factor structure.

3.5. Reliability analysis of the SWLS scales

The internal consistency of the SWLS in the total sample ($n = 483$) was 0.86. This indicated adequate internal

Table 3
Intercorrelations for SWLS with PANSI-Negative, PANSI-Positive, RSE, AHT, PSR, RFL, BHS and DASS.

Variables	RFL	RSE	AHT	PSR	PANPO	PANNEG	BHS	DASS
SWLS	.371**	.502**	.372**	.472**	.508**	-.412**	-.533**	-.515**

SWLS, Satisfaction With Life Scale; RFL, Reasons For Living Inventory; RSE, Rosenberg Self-Esteem Scale; AHT, The Adult Trait Hope Scale; PSR, Provision of Social Relations; PANPO, Positive and Negative Suicide Ideation Inventory (PANSI-Positive); PANNEG, Positive and Negative Suicide Ideation Inventory (PANSI-Negative); BHS, Beck Hopelessness Scale; DASS, The Depression Anxiety Stress Scale.

** Pearson correlation coefficient, $p < .001$.

Table 4
Discriminant analyses of SWLS.

	<i>B</i>	S.E.	Wald	<i>df</i>	Sig.	Exp(<i>B</i>)	95.0% CI for EXP(<i>B</i>)	
							Lower	Upper
TSWL	-.115	.018	41.172	1	<.001**	.891	.860	.923
Constant	.614	.356	2.966	1	.085	1.848		

SWLS, Satisfaction With Life Scale; TSWL, total Satisfaction With Life Scale; *df*, degree of freedom; Sig., significance probability; S.E., standard error; CI, confidence interval.

** $p < .001$.

consistency based on the suggested criterion level for a coefficient’s alpha of 0.70 and above by Nunnally and Bernstein [21] in 1994. The inter-item correlations ranged from 0.48 to 0.76 and this indicated that there was lack of multicollinearity since the value was below 0.80 [18].

3.6. Concurrent validity

Concurrent validity was evaluated using the Pearson correlation coefficient. The descriptions of the scales and their inter-correlations are shown in Table 3. When high correlation is obtained between measures of a similar construct, it indicates good concurrent validity. Scales measuring protective factors for suicidal behavior in this study include PANSI-Positive, RSE, ATH, PSR and RFL. Meanwhile scales measuring risk factor include PANSI-Negative, BHS and DASS. The results revealed a strong positive relationship between the total score of SWLS with measure of protective factors, PANSI-Positive, RSE, PSR and a moderate positive relationship with AHT and RFL. Meanwhile, a strong negative relationship was found between the total score of SWLS with measure of risk factors, DASS, BHS and PANSI-Negative. This illustrated that the SWLS holds good concurrent validity.

3.7. Discriminative validity

In order to evaluate the contribution of SWLS in differentiating between patients who attempted suicide (coded as 1) and patients who did not attempt suicide (coded as 0), a logistic regression analysis was used. In the comparison between patients who attempted suicide and control group, scores of SWLS (estimate = $-.115$, $p < .05$, $OR = 0.891$, $95\% CI = 0.86–0.92$) (see Table 4) were identified as significant indicating that the SWLS is useful

Table 5
Mean score and standard deviation of SWLS for psychiatry and medical patients.

	Psychiatric patients, mean \pm SD	Medical patients, mean \pm SD
SWLS	20.5 \pm 7.67	25.4 \pm 6.00**

SWLS, Satisfaction With Life Scale; SD, standard deviation.

** $p < .001$.

risk instrument in differentiating these two groups. SWLS had an overall classification accuracy estimate was 85.2%.

3.8. Criterion validity

Table 5 shows that the medical patients demonstrated significantly higher mean scores on the SWLS than the psychiatric patients (see Table 5). This showed that the SWLS has good criterion validity.

4. Discussion

The goal of the present study was to evaluate the factor structure and psychometric properties of SWLS on psychiatry and medical outpatients in Malaysia. Confirmatory factor analysis revealed a uni-dimensional solution based on most model fit indices. This finding was in line with numerous previous studies in different samples (556 Chinese; 442 American students; 487 Israel adults; 1700 healthy Dutch young adults; 2080 Spanish junior high students; 1554 Malay-speaking community sample) supporting the uni-dimensional factor model [5,12–15].

The single factor of the five-itemed SWLS had the total variance of 67.58, which appears to be unique. It should be noted that the reliability and validity of SWLS were not affected even though the sample consisted of Malays, Chinese and Indian with different cultural background and religion. These results suggested that the culture and religious differences among participants did not appear to influence their evaluations of their life satisfaction. In addition, patients who participated in this study (98.3%) were with the education level of at least high school certificate level and this would have helped them in understanding the questionnaire better in evaluating their satisfaction with life. Swami and Chamooro-Premuzic [15] reported that the SWLS was a valid and reliable measure of life satisfaction for Malay-speaking samples in Malaysia. Meanwhile, SWLS was reported to be useable among Chinese in Taiwan [22] and Hong Kong [23].

The SWLS factor proved to have high internal consistency, with Cronbach α reaching 0.86. This result is consistent with findings by Arrindell et al. [10] whereby the internal consistency for SWLS was 0.87 in a non-psychiatric medical outpatients sample and other previous studies (e.g. [8,15,20]). In contrast to our findings, Howell et al. [24] reported low internal reliability for SWLS (in

question-format) among an Orang Asli sample in Peninsular Malaysia. According to the authors, the finding was likely due to several factors. The Orang Asli sample had a very low basic education level and they may not have been fluent in Bahasa Malaysia. In addition, this group may have been unfamiliar with psychological testing. Logistic regression showed that SWLS had good discriminative validity whereby the scale was able to differentiate patients with suicide attempts and without suicide attempt. In addition, SWLS had good criterion validity with the mean score of SWLS and was found to be significantly higher among medical patients compared to psychiatric patients. Gouveia et al. [25] reported that criterion validity for SWLS was positively related with positive effect and negatively with negative effect. The results study further verified the concurrent validity of SWLS with a significant positive correlation between SWLS total score with measure of protective factors, PANSI-Positive, RSE, ATH, PSR and RFL. Durak et al. [26] reported that SWLS had good concurrent validity in a sample of university students, correctional officers and elderly adults. The scores of the participants were positively correlated with self-esteem, monthly income and perceived current health status and were negatively correlated with late-life depression. Meanwhile a significant negative correlation was found between SWLS total score with measure of risk factors, DASS, BHS and PANSI-Negative.

This is one of the first studies to validate the SWLS among psychiatry and medical outpatients for use in an Asian country. This study provides evidence that SWLS is a reliable and valid measure of satisfaction of life for use in the Malaysian context. The major strengths of the present study included the use of EFA and CFA methodology and the direct application of a theoretically derived measure to a clinical setting and a specific sample. In addition to this, cross-validation of different clinical samples for CFA strengthens the robustness of this study.

It can be concluded from the results that SWLS can be used with confidence in future research and clinical use in Malaysia especially among psychiatry and medical outpatients.

Acknowledgment

We would like to thank the Government of Malaysia and the University of Kebangsaan Malaysia for providing a scholarship to Aishvarya Sinniah to complete her PhD degree at the University of Queensland, Australia; We are grateful to the patients who volunteered to participate in this study; Dr. Oei is an Emeritus Professor at the University of Queensland, Australia and he is also a part-time visiting Professor of Clinical Psychology at James Cook University in Singapore when this paper was completed; and to thank the staff of Department of Psychiatry, Faculty of Medicine, Universiti Kebangsaan Malaysia Medical Centre, Malaysia

and School of Psychology at University of Queensland, Australia for their help.

References

- [1] Lucas RE, Diener E, Suh E. Discriminant validity of well-being measures. *J Pers Soc Psychol* 1996;71(3):616-28.
- [2] Pavot W, Diener E. Review of the Satisfaction With Life Scale. *Psychol Assess* 1993;5:164-72.
- [3] Diener E, Emmons RA, Larsen RJ, Griffin S. The Satisfaction With Life Scale. *J Pers Assess* 1985;49:71-5.
- [4] Shin DC, Johnson DM. A vowed happiness as an overall assessment of the quality of life. *Soc Indicators Res* 1978;5:475-92.
- [5] Oishi S. The concept of life satisfaction across cultures: an IRT analysis. *J Res Pers* 2006;40:411-23.
- [6] Neto F. The Satisfaction with Life Scale—psychometric properties in an adolescent sample. *J Youth Adolesc* 1993;22:125-34.
- [7] Lewis CA, Bunting BP, Shevlin ME, Joseph S. Confirmatory factor-analysis of the Satisfaction With Life Scale—replication and methodological refinement. *Percept Mot Skills* 1995;80:304-6.
- [8] Glaesmer H, Grande G, Braehler E, Roth M. The German Version of the Satisfaction with Life Scale (SWLS). Psychometric properties, validity, and population-based norms. *Eur J Psychol Assess* 2011;27(2):127-32.
- [9] Vassar M. A note on the score reliability for the Satisfaction with Life Scale: an RG study. *Soc Indicators Res* 2008;86:47-57.
- [10] Arrindell WA, Meeuwesen L, Huyse FJ. The Satisfaction With Life Scale (SWLS)—psychometric properties in a non psychiatric medical outpatients sample. *Pers Individ Differ* 1991;12:117-23.
- [11] Larsen RJ, Diener E, Emmons RA. An evaluation of subjective well-being measures. *Soc Indicators Res* 1985;17:1-17.
- [12] Anaby D, Jarus T, Zumbo B. Psychometric evaluation of the Hebrew language version of the Satisfaction with Life Scale. *Soc Indicators Res* 2010;96:267-74.
- [13] Arrindell WA, Heesink J, Feij JA. The Satisfaction With Life Scale (SWLS): appraisal with 1700 healthy young adults in the Netherlands. *Pers Individ Differ* 1999;26:815-26.
- [14] Atienza FL, Balaguer I, Garcia-Merita ML. Satisfaction With Life Scale: analysis of factorial invariance across sexes. *Pers Individ Differ* 2003;35:1255-60.
- [15] Swami V, Chamorro-Premuzic T. Psychometric evaluation of the Malaysian Satisfaction With Life Scale. *Soc Indicators Res* 2009;92:25-33.
- [16] Sheehan DV, Lecrubier Y, Sheehan KH, Amorim P, Janavs J, Weiller E, et al. The M.I.N.I. (Mini International Neuropsychiatric Interview). *Clin Psychiatry* 1998;59(20):22-33.
- [17] Browne MW, Cudeck R. Alternative ways of assessing model fit. *Sociological Methods Res* 1993;21:230-58.
- [18] Tabachnick BG, Fidell LS. Using multivariate statistics, 5th edn. Boston (Mass): Allyn & Bacon; 2007.
- [19] Kaiser H. A second generation Little Jiffy. *Psychometrika* 1970;39:31-6.
- [20] Bai W, Wu C, Zheng R, Ren X. The psychometric evaluation of the Satisfaction With Life Scale using a nationally representative sample of China. *J Happiness Stud* 2011;12:183-97.
- [21] Nunnally JC, Bernstein IH. *Psychometric theory*. New York: McGraw-Hill; 1994.
- [22] Wu CH, Yao G. Analysis of factorial invariance across gender in the Taiwan version of the Satisfaction With Life Scale. *Pers Individ Differ* 2006;40:1259-68.
- [23] Sachs J. Validation of the Satisfaction With Life Scale in a sample of Hong Kong University. *Psychologia: An International Journal of Psychology in the Orient* 2004;46:225-34.
- [24] Howell CJ, Howell RT, Schawabe KA. Does wealth enhance life satisfaction for people who are materially deprived? Exploring the association among the Orang Asli of Peninsular Malaysia. *Soc Indicators Res* 2006;76:499-524.
- [25] Gouveia VV, Milfont TL, Fonseca PN, Coelho JA. Life satisfaction in Brazil: testing the psychometric properties of the Satisfaction With Life Scale (SWLS) in five Brazilian samples. *Soc Indicators Res* 2009;90:267-77.
- [26] Durak M, Senol-Durak E, Gencoz T. Psychometric properties of the Satisfaction With Life Scale among Turkish university students, correctional officers, and elderly adults. *Soc Indicators Res* 2010;99:413-29.